



# WS400H SPEAKER

**WHELEN**  
MANUFACTURED IN AMERICA

## ECONOMICAL SPEAKER FOR MASS NOTIFICATION APPLICATIONS

Whelen's unique WS400H Speaker is a single, 400 watt speaker, the only one of its kind in the Mass Notification industry.

### FEATURES

- 400 watt speaker driver
- Weather-proof, fiberglass speaker flare
- Powder painted, spun aluminum re-entrant horn section
- Corrosion-resistant, cast aluminum housing provides a protective, weather-proof enclosure for the driver and wiring terminals
- Two feet of 16AWG, 2/C cable exits through the bottom of the speaker for field wiring
- Heavy-duty, painted bracket allows installer to flush mount the speaker and angle it down approximately 15 degrees
- Optional pole mount bracket (WS400HPM) is available
- Cable is available - 14AWG for 0-100' runs, 12AWG for 100'-200' runs

### ACOUSTIC

Wattage: 400 watts

Estimated 70dB Range: 2,400 ft / 732 m

Weather, terrain and other structures may impact the range. Each siren within the system may have a decreased or increased range depending on conditions beyond our control.

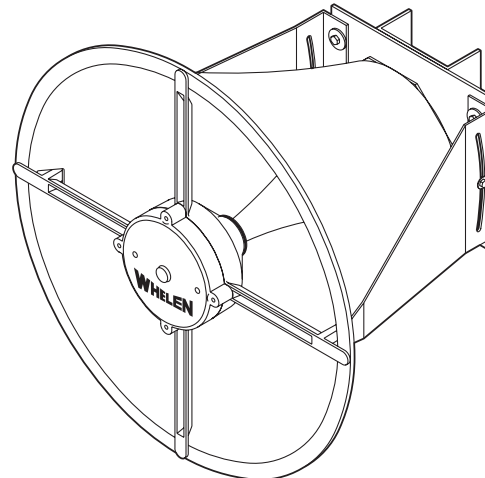

WS400H Speaker  
with optional WS400HPM  
pole mounting kit attached



WS400H  
400 Watt  
Speaker



# WS400H SPEAKER

**WHELEN**  
MANUFACTURED IN AMERICA

## DIMENSIONS

"Our Mass Notification Products Speak for Themselves™"

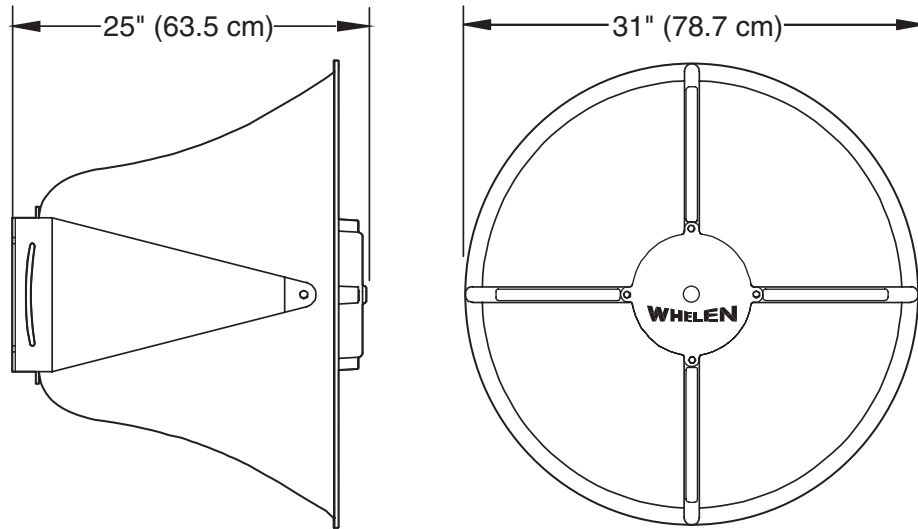

WS400H Speaker with standard wall mounting bracket

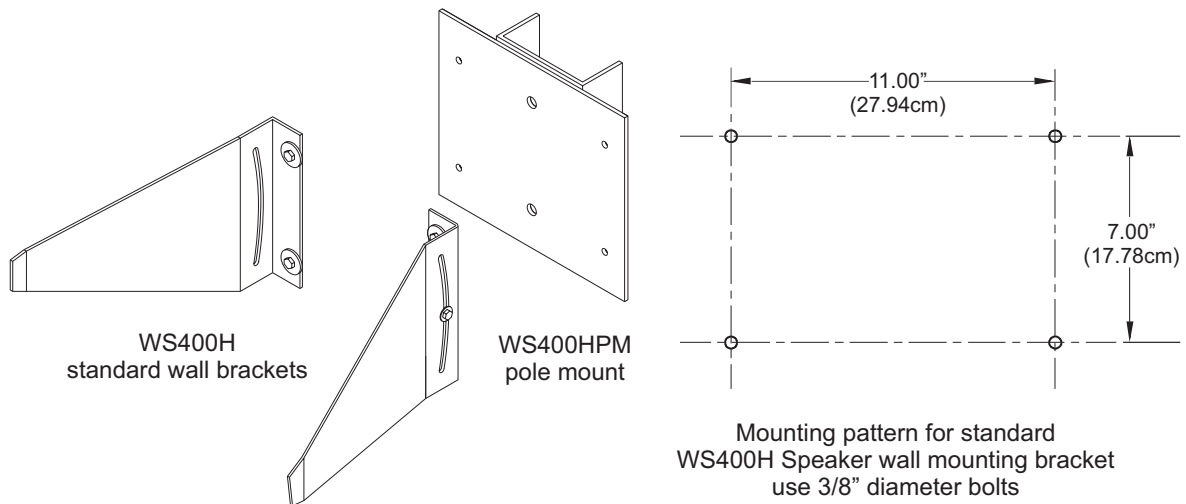

ISO 9001 REGISTERED QMS      @WhelenENG

Mass Notification Products | Whelen Engineering Company, Inc.  
51 Winthrop Road, Chester, Connecticut 06412-0684 | 860-526-9504 | 800-637-4736  
www.whelenmassnotification.com | iowasales@whelen.com

Whelen Engineering Company, Inc. reserves the right to upgrade its products with design improvements without notification. © 2022 Whelen Engineering Company, Inc. Printed in the U.S.A. MS12171G - 12/22

 **WARNING:** This product may contain chemicals known to the State of California to cause cancer and birth defects or other reproductive harm. For more information, visit [whelen.com/regulatory](http://whelen.com/regulatory).