



ALL HAZARD IN-PLANT PERSONAL WARNING SYSTEM

Whelen's IPS Series products deliver clear, powerful voice and tone warnings, eliminating confusion at the onset of an emergency.

SYSTEM FEATURES

- IPS400 / IPS800
- Two compartment (Type I) natural finish aluminum cabinet
- Public address and pre-recorded voice message capability
- Battery powered with UPS style cell batteries
- AC temperature compensated 5 amp battery charger
- Local or remote controls available
- One or two power amplifier(s) (one for IPS400, two for IPS800)
- Electronic controller
- Tone Generator Timer
- Local control push-buttons
- Lightning arrestor
- Six standard warning tones:
 - Wail, Whoop, Alert, Attack, Hi-Lo, Airhorn
- RDVM1G, Digital voice option, 1-28 message capable

SYSTEM OPTIONS

- Microphone – for use at the cabinet (locally) or at the control point (remotely)

ACTIVATION CONTROLS

Our VHF and UHF radio narrow-band control packages feature Whelen protocol COMM/STAT™ and include the following:

- Radio
- Radio interface
- Tone or digital squelch
- 3-5 dB gain omni-directional antenna with bracket
- 35' (10.67m) of RG58 antenna cable
- Polyphaser
- Low battery alarm (two-way only)

Other features are dependent upon one or two-way controls. Whelen equipment can be interfaced with many different types of two-way radio communications products and systems, from ACE, MOSCAD and FSK.

The following is available as standard options. **BLACK BOLD** indicates the Whelen Model:

One-Way Controls

- **AUXIN** – Auxilliary board for contact closure activation
- **D2030LL** – 10 digit DTMF Landline
- **D2030NV** – 10 digit DTMF VHF High-Band Narrow-Band/138-174 MHz
- **D2030NU** – 10 digit DTMF UHF Narrow-Band /450-470 MHz
- **WPSTT** – Two-tone sequential option (one-way radio package must be ordered from above options) /450-470 MHz

Two-Way Controls

- **AUXCS** – Two-way contact closure activation and status board
- **C2030LL** – Two-way landline activation
- **C2030NV** – 10 digit DTMF VHF High-Band Narrow-Band/138-174 MHz
- **C2030NU** – 10 digit DTMF UHF Narrow-Band

Options

- **PGINT** – Paging interface
- **INTRU** – Intrusion alarm

SPEAKER OPTIONS

- **WS15T** – Pedestal mount, 15 watt speaker
- **WS30T** – Pedestal mount, 30 watt speaker
- **WS15TR** – Recess mount, 15 watt speaker
- **WS15TEN** - Recess mount, 15 watt speaker with grille
- **WS60T** – Wide-angle, 60 watt speaker
- **WS100** – Wide-angle, 100 watt speaker
- **WS100TCH** – Wide-angle, 100 watt speaker with weatherproof housing
- **WSXPL60T3** – Wide-angle, Explosion-proof, 60 watt speaker

All of the above speakers (except WS100) include level adjustment multi-tap transformers and a capacitor for line level supervision.



Type I Electronic Cabinet



IPS400 & IPS800



SPECIFICATIONS

"Our Mass Notification Products Speak for Themselves™"

Model	Height Inches (CM)	Width Inches (CM)	Depth Inches (CM)	Weight Lbs. (kg)
IPS400	37.13 (94.3)	22.75 (57.8)	10.7 (27.1)	120 (54.4)
IPS800	37.13 (94.3)	22.75 (57.8)	10.7 (27.1)	160 (72.6)

ELECTRICAL

- **AC Input:** 120 / 240V, 60Hz, 7A fuse
- **DC Output:** 28VDC @ 5 amp.
- **Power Amplifier:** 400 watts, 4 output channels per amplifier
- **Tone Generation:** 6 warning signals, standard
- **Public Address:** Standard

SPEAKER OPTIONS



WS15T / WS30T - Weatherproof, 15 or 30 watt re-entrant loud speakers with multi-tapped, line matching transformers for output adjustment. Includes pedestal mounting bracket for vertical or horizontal installation.

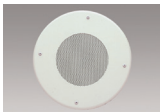

WS15TR / WS15TEN - 15 watt re-entrant loud speakers with multi-tapped, line matching transformers for output adjustment. Ideal for recessed mounting applications.



WS60T / WS100 (shown) - Heavy-duty 60 watt or 100 watt re-entrant loud speaker with wide-angle horn. Mounting bracket is included for vertical, horizontal or stacked installations.



WS100TCH - Heavy-duty, waterproof, 100 watt wide-angle re-entrant loud speakers with multi-tapped, line matching transformers for output adjustment. Rugged cast aluminum housing. Includes mounting bracket for horizontal or vertical installations.



WSXPL60T3 - For explosive or combustible atmospheres. 60 watt re-entrant, wide-angle loud speaker features a heavy-duty cast aluminum housing. Includes mounting bracket for horizontal or vertical installations, and multi-tapped line matching transformer. Specify environment by Class and Group when ordering.

ORDERING INFORMATION

Basic System Includes the Following:

IPS400/IPS800 – Electronics cabinet including voice board for 1-28 pre-recorded messages

Speakers:

- **WS15T** – Pedestal mount, 15 watt speaker
- **WS30T** – Pedestal mount, 30 watt speaker
- **WS15TR** – Recess mount, 15 watt speaker
- **WS15TEN** – Recess mount, 15 watt speaker with grille
- **WS60T** – Wide-angle, 60 watt speaker
- **WS100** – Wide-angle, 100 watt speaker
- **WS100TCH** – Wide-angle, 100 watt speaker with weatherproof housing
- **WSXPL60T3** – Wide-angle, Explosion-proof, 60 watt speaker

Options:

- **AUXIN** (one-way)/**AUXCS** (two-way) – Auxiliary boards for contact closure activation
- **D2030LL/D2030NV/D2030NU** – One-way controls
- **C2030LL/C2030NV/C2030NU** – Two-way controls
- **WPSTT** – Two-tone sequential
- **PGINT1** – Paging interface
- **INTRU** – Intrusion alarm (two-way only)
- **MSGPROG** – Custom pre-recorded messages
- **MSGPROGL** – Whelen Library messages
- **WPSNCMIC** – Microphone for public address use at the cabinet

A SYSTEM APPROACH

A facility has two main control centers monitoring plant operations. One plant area is used for light manufacturing and office operations. This requires many low powered speakers allocated over several zones. The second plant area includes heavy manufacturing with high ambient noise levels and requires powerful speakers and visual alerting. In this area alarms may also require local activation. The system diagram below illustrates one solution for the application

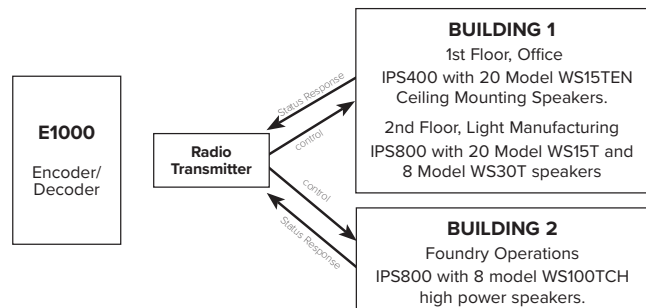

ISO 9001 REGISTERED QMS

Mass Notification Products | Whelen Engineering Company, Inc.
51 Winthrop Road, Chester, Connecticut 06412-0684 | 860-526-9504 | 800-637-4736
www.whelenmassnotification.com | iowasales@whelen.com

Whelen Engineering Company, Inc. reserves the right to upgrade its products with design improvements without notification. © 2022 Whelen Engineering Company, Inc. Printed in the U.S.A. MS10257J - 05/23

WARNING: This product may contain chemicals known to the State of California to cause cancer and birth defects or other reproductive harm. For more information, visit whelen.com/regulatory.