

# **WHELEN<sup>®</sup>**

**ENGINEERING COMPANY INC.**

*51 Winthrop Road*

*Chester, Connecticut 06412-0684*

*Phone: (860) 526-9504*

*Internet: [www.whelen.com](http://www.whelen.com)*

*Sales e-mail: [lowsales@whelen.com](mailto:lowsales@whelen.com)*

*Customer Service e-mail: [iowserv@whelen.com](mailto:iowserv@whelen.com)*

# **Model WS15TEN**

# **Speaker Assembly**

## **Product Description**

**Mass Notification**

**GENERAL-**

Whelen Model WS15TEN is a 15 watt speaker assembly intended for use in personnel warning applications, where interior, flush-mounted ceiling installation is required.

The speaker consists of all metal construction. All exposed metal parts are plated, to eliminate corrosion. The speaker incorporates a high efficiency double re-entrant loudspeaker.

The WS15TEN comes with a round speaker grille, a round recessed enclosure and a mounting ring for 24" ceiling tile.

The speaker grille has a fine textured, white painted finish and includes four white mounting screws.

An internal multi-tap line transformer allows for output power level adjustment.

**INSTALLATION-**

The WS15TEN is shipped fully assembled. It must be partially disassembled to install and wire.

Determine the location of the speaker, typically at the center of a 24" ceiling tile. Remove the ceiling tile. Cut a 10" circle in the center of the tile.

Remove the four white screws from the grille. Separate the speaker/grille assembly from the enclosure/mounting ring assembly. Locate the enclosure/mounting ring assembly on the ceiling grid. Remove one of the 1/2" knock outs.

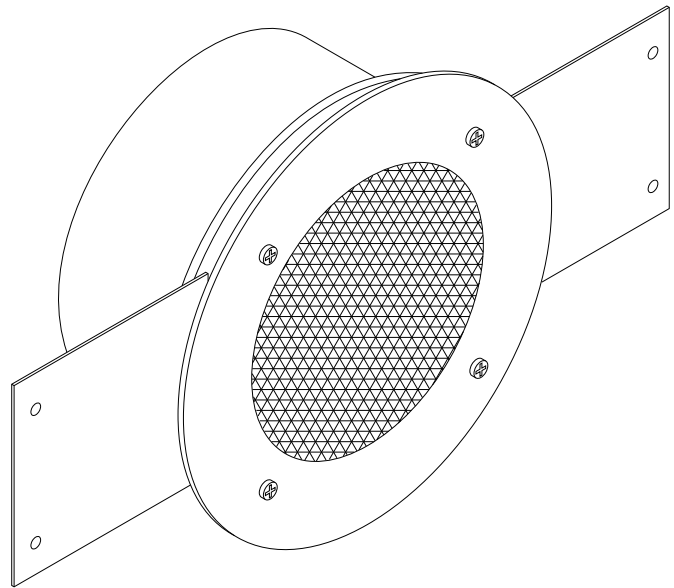

Install a conduit clamp and route the speaker wire into the enclosure. Re-install the ceiling tile under the enclosure/mounting ring.

Connect the speaker cable to the speaker driver. Notice that the terminals are marked 1 and 2. Speaker connections are:

- Speaker (-) wire to Terminal 1
- Speaker (+) wire to Terminal 2

Select the output transformer setting. Re-install the speaker/grille assembly.

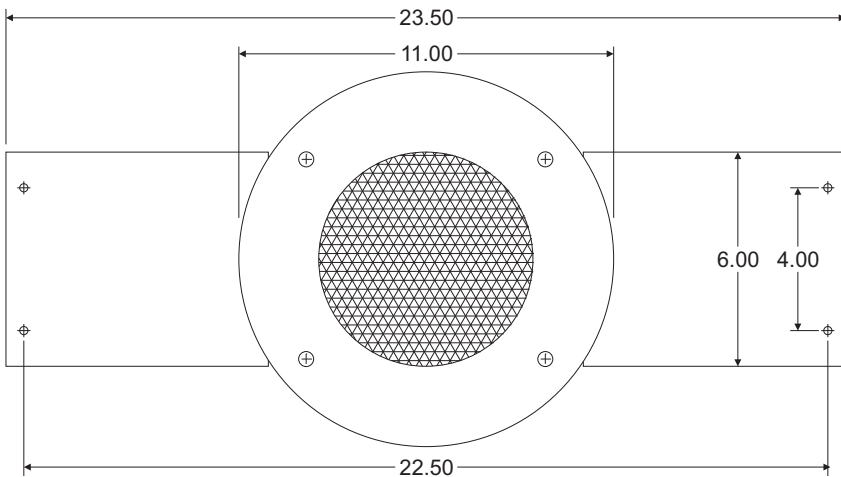

- Notes:**
1. Not for use in classified areas.
  2. SPL readings are ± 1dBA.
  3. Measurement based on Whelen Amplifier 01-0285564-00C.

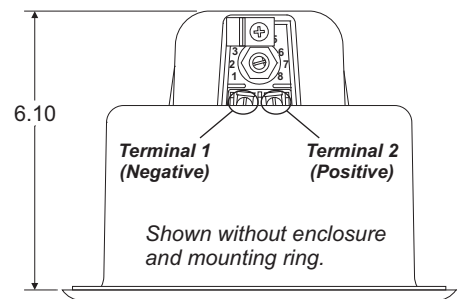

**WS15TEN SPEAKER ASSEMBLY**

**PRODUCT SPECIFICATIONS**

**Dimensions of enclosure**

Height: 8" (20.3 cm)  
 Diameter: 10.5" (26.7 cm)  
 Weight: 3.5 lbs. (1.6 kg)

(see drawing above for mounting ring)

**Dimensions of grille**

Diameter: 11" (27.9 cm)  
 Height: .3" (.8 cm)

**Finish**

Grille: White, fine texture paint  
 Enclosure: Black

**Performance (at 4 feet, 500 Hz)**

SPL:	Tap	Watts	dBA
	1	.24	90
	2	.48	93
	3	.95	95
	4	1.9	98
	5	3.8	101
	6	Do Not Use	
	7	Do Not Use	

Dispersion: 180°