

51 Winthrop Road
Chester, Connecticut 06412-0684
Phone: (860) 526-9504
Sales Email:autosale@whelen.com
Canadian Sales:canadiansales@whelen.com
Customer Service:custserv@whelen.com

Safety First: This document provides all the necessary information to allow your Whelen product to be properly and safely installed. Before beginning the installation and/or operation of your new product, the installation technician and operator must read this manual completely. Important information is contained herein that could prevent serious injury or damage.

- Proper installation of this product requires the installer to have a good understanding of automotive electronics, systems and procedures.
- Whelen Engineering requires the use of waterproof butt splices and/or connectors if that connector could be exposed to moisture.
- Failure to use specified installation parts and/or hardware will void the product warranty!
- If mounting this product requires drilling holes, the installer MUST be sure that no vehicle components or other vital parts could be damaged by the drilling process. Check both sides of the mounting surface before drilling begins. Also de-burr any holes and remove any metal shards or remnants. Install grommets into all wire passage holes.
- Do not install this product or route any wires in the deployment area of your air bag. Equipment mounted or located in the air bag deployment area will damage or reduce the effectiveness of the air bag, or become a projectile that could cause serious personal injury or death. Refer to your vehicle owner's manual for the air bag deployment area. The User/Installer assumes full responsibility to determine proper mounting location, based on providing ultimate safety to all passengers inside the vehicle.
- For this product to operate at optimum efficiency, a good electrical connection to chassis ground must be made. The recommended procedure requires the product ground wire to be connected directly to the NEGATIVE (-) battery post.
- Do not attempt to activate or control this device in a hazardous driving situation.
- If this product uses a remote device to activate or control this product, make sure that this control is located in an area that allows both the vehicle and the control to be operated safely in any driving condition.
- This product contains either strobe light(s), halogen light(s), high-intensity LEDs or a combination of these lights. Do not stare directly into these lights. Momentary blindness and/or eye damage could result..
- Use only soap and water to clean the outer lens. Use of other chemicals could result in premature lens cracking (crazing) and discoloration. Lenses in this condition have significantly reduced effectiveness and should be replaced immediately. Inspect and operate this product regularly to confirm its proper operation and mounting condition. Do not use a pressure washer to clean this product.
- **WARNING!** All customer supplied wires that connect to the positive (+) terminal of the battery must be sized to supply at least 125% of the maximum operating current and FUSED "at the battery" to carry that load. **DO NOT USE CIRCUIT BREAKERS WITH THIS PRODUCT!**
- **FAILURE TO FOLLOW THESE PRECAUTIONS AND INSTRUCTIONS COULD RESULT IN DAMAGE TO THE PRODUCT OR VEHICLE AND/OR SERIOUS INJURY TO YOU AND YOUR PASSENGERS!**

Mounting (Universal Bracket)

1. Place the bracket against the mounting surface and mark the two mounting hole locations. **Confirm that no vehicle parts could be damaged by the drilling process.**
2. Drill two mounting holes sized for a #8 sheet metal screw. A wire passage hole may also be needed. De-burr this hole and install a grommet to protect the wires.
NOTE: If you use the VHB tape, remove the protective backing and press it firmly onto the bottom of the bracket. Clean mounting surface with 50/50 mix of isopropyl alcohol and water.
3. Route the wires through the hole in the bracket and through the wire passage hole. Secure the ION™ to the bracket using the hardware provided. Wire as outlined below.

Mounting (Gripper Bracket)

1. Apply the protective pads in the location shown (side view). Secure the ION™ to the bracket in the same fashion as outlined for the standard bracket.
2. Position the bracket onto the proposed mounting surface as shown. Apply a drop of Loctite 222 to the threads of the #6 x 1/2" PPHMS provided.
3. Thread screws into underside of bracket and secure bracket to mounting surface.

Wiring

(BLK) Ground - Extend the BLK wire to Chassis Ground.

(RED) Warning Light - Extend the RED wire to +12VDC via an SP/ST switch (Fuse at 3 amps).

(WHT/VIO) Scan-Lock™ - Extend the WHT/VIO wire to +12VDC via a momentary switch (1 amp fuse). Refer to the Scan-Lock section for operational information.

(GREY) SYNC - To SYNC 2 lighthoods, configure both lighthoods to display the same Phase 1 (Simultaneous) pattern. Turn power off and connect the GREY wire from each lighthood together. Activate the lighthoods and their patterns will be synchronized. To configure 2 lighthoods to alternate their patterns, advance either lighthood to Phase 2 (Alternating) of the current pattern.

(WHT/BLK) Steady - Extend the WHT/BLK wire to +12VDC via an SP/ST switch. (3amp fuse)

(YEL) - Mode - Extend the YEL wire to +12VDC via a momentary switch (1 amp fuse).

Mode Programming: This lighthood will operate in seven different modes. Mode selection works the same as ScanLock using the YEL wire instead of the WHT/VIO.

MODE 1: Color 1 will activate. **MODE 2:** Color 2 will activate. **MODE 3:** Color 3 will activate. **MODE 4:** Colors 1 & 2 will activate. **MODE 5:** Colors 1 & 3 will activate. **MODE 6:** Colors 2 & 3 will activate. **MODE 7:** Colors 1, 2 & 3 will activate.

Scan-Lock

Note: In order to change flash patterns, the lighthood must be on.

To advance to the next pattern: Apply +12VDC to the WHT/VIO wire for less than 1 second and release.

To cycle back to the previous pattern: Apply +12VDC to the WHT/VIO wire for more than 1 second and release.

To change the Default Pattern: When the desired pattern is displayed, allow it to run for more than 5 seconds. The lighthood will now display this pattern when initially activated.

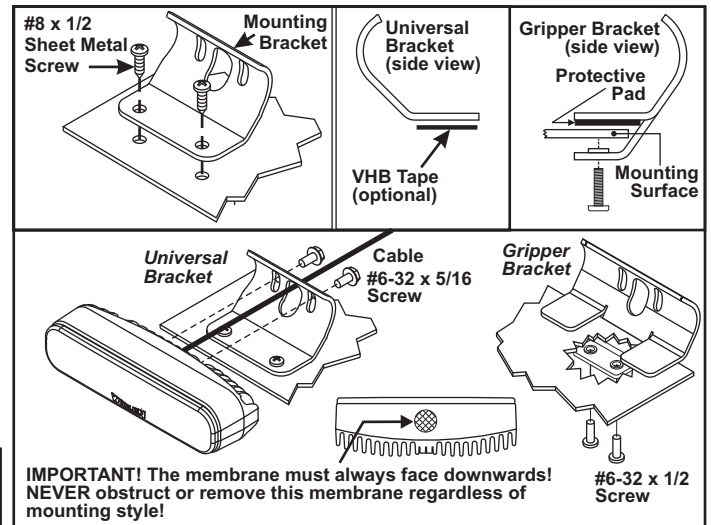

To restore the factory default pattern: With the light turned off, apply power to the WHT/VIO wire. With power applied to the WHT/VIO wire, turn light on. Allow the unit to run for 3 seconds before removing power from the WHT/VIO wire. This will reset all patterns back to their default settings.

Flash Patterns (SYNC)

- | | | |
|------------------------------|----------------------------------|--------------------------|
| 1. SignalAlert™ 75 / phase 1 | 12. LongBurst 75 / phase 2 | 22. TripleFlash 75 |
| 2. SignalAlert 75 / phase 2 | 13. PingPong™ 75 / phase 1 | 23. TripleFlash 120 |
| 3. CometFlash® 75 / phase 1 | 14. PingPong 75 / phase 2 | 24. ActionFlash™ 50 |
| 4. CometFlash 75 / phase 2 | | 25. ActionFlash™ 150 |
| 5. DoubleFlash 75 / phase 1 | Flash Patterns (NON SYNC) | 26. Cal SignalAlert |
| 6. DoubleFlash 75 / phase 2 | 15. SingleFlash 60 | 27. Action SingleFlash 1 |
| 7. SingleFlash 75 / phase 1 | 16. SingleFlash 90 | 28. Action SingleFlash 2 |
| 8. SingleFlash 75 / phase 2 | 17. SingleFlash 120 | 29. Cal Scan™ |
| 9. ComAlert™ 75 / phase 1 | 18. SingleFlash 300 | 30. ModuFlash™™ |
| 10. ComAlert 75 / phase 2 | 19. DoubleFlash 120 | 31. ActionScan™ |
| 11. LongBurst™ 75 / phase 1 | 20. ComAlert 150 | 32. Cal Comet™™ |
| | 21. PingPong 120 | 33. Steady |

BOLD = California Title XIII compliant

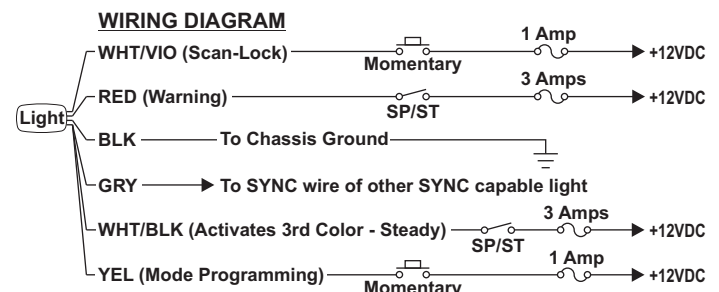

Warnings to Installers

Whelen's emergency vehicle warning devices must be properly mounted and wired in order to be effective and safe. Read and follow all of Whelen's written instructions when installing or using this device. Emergency vehicles are often operated under high speed stressful conditions which must be accounted for when installing all emergency warning devices. Controls should be placed within convenient reach of the operator so that he can operate the system without taking his eyes off the roadway. Emergency warning devices can require high electrical voltages and/or currents. Properly protect and use caution around live electrical connections. Grounding or shorting of electrical connections can cause high current arcing, which can cause personal injury and/or vehicle damage, including fire. Many electronic devices used in emergency vehicles can create or be affected by electromagnetic interference. Therefore, after installation of any electronic device it is necessary to test all electronic equipment simultaneously to insure that they operate free of interference from other components within the vehicle. Never power emergency warning equipment from the same circuit or share the same grounding circuit with radio communication equipment. All devices should be mounted in accordance with the manufacturer's instructions and securely fastened to vehicle elements of sufficient strength to withstand the forces applied to the device. Driver and/or passenger air bags (SRS) will affect the way equipment should be mounted. This device should be mounted by permanent installation and within the zones specified by the vehicle manufacturer, if any. Any device mounted in the deployment area of an air bag will damage or reduce the effectiveness of the air bag and may damage or dislodge the device. Installer must be sure that this device, its mounting hardware and electrical supply wiring does not interfere with the air bag or the SRS wiring or sensors. Mounting the unit inside the vehicle by a method other than permanent installation is not recommended as unit may become dislodged during swerving; sudden braking or collision. Failure to follow instructions can result in personal injury. Whelen assumes no liability for any loss resulting from the use of this warning device. **PROPER INSTALLATION COMBINED WITH OPERATOR TRAINING IN THE PROPER USE OF EMERGENCY WARNING DEVICES IS ESSENTIAL TO INSURE THE SAFETY OF EMERGENCY PERSONNEL AND THE PUBLIC.**

Warnings to Users

Whelen's emergency vehicle warning devices are intended to alert other operators and pedestrians to the presence and operation of emergency vehicles and personnel. However, the use of this or any other Whelen emergency warning device does not guarantee that you will have the right-of-way or that other drivers and pedestrians will properly heed an emergency warning signal. Never assume you have the right-of-way. It is your responsibility to proceed safely before entering an intersection, driving against traffic, responding at a high rate of speed, or walking on or around traffic lanes. Emergency vehicle warning devices should be tested on a daily basis to ensure that they operate properly. When in actual use, the operator must ensure that both visual and audible warnings are not blocked by vehicle components (i.e.: open trunks or compartment doors), people, vehicles, or other obstructions. It is the user's responsibility to understand and obey all laws regarding emergency warning devices. The user should be familiar with all applicable laws and regulations prior to the use of any emergency vehicle warning device. Whelen's audible warning devices are designed to project sound in a forward direction away from the vehicle occupants. However, because sustained periodic exposure to loud sounds can cause hearing loss, all audible warning devices should be installed and operated in accordance with the standards established by the National Fire Protection Association.