

# WHELEN<sup>®</sup>

## ENGINEERING COMPANY INC.

51 Winthrop Road  
Chester, Connecticut 06412-0684  
Phone: (860) 526-9504  
Internet: [www.whelen.com](http://www.whelen.com)  
Sales e-mail: [autosale@whelen.com](mailto:autosale@whelen.com)  
Customer Service e-mail: [custserv@whelen.com](mailto:custserv@whelen.com)

**Installation Guide:**  
**EB6 Power Supply Kit Retro-fit**  
**Edge<sup>®</sup> Model(s) 9004SL, 9004WB, 9801, 9802, 9804, 9806,**  
**Mini Edge<sup>®</sup>, 9104, 9206, 9206WB, 9308, 9308WB, 9000FM**

### Warnings to Installers

Whelen's emergency vehicle warning devices must be properly mounted and wired in order to be effective and safe. Read and follow all of Whelen's written instructions when installing or using this device. Emergency vehicles are often operated under high speed stressful conditions which must be accounted for when installing all emergency warning devices. Controls should be placed within convenient reach of the operator so that they can operate the system without taking their eyes off the roadway. Emergency warning devices can require high electrical voltages and/or currents. Properly protect and use caution around live electrical connections. Grounding or shorting of electrical connections can cause high current arcing, which can cause personal injury and/or vehicle damage, including fire. Many electronic devices used in emergency vehicles can create or be affected by electromagnetic interference. Therefore, after installation of any electronic device it is necessary to test all electronic equipment simultaneously to insure that they operate free of interference from other components within the vehicle. Never power emergency warning equipment from the same circuit or share the same grounding circuit with radio communication equipment. All devices should be mounted in accordance with the manufacturer's instructions and securely fastened to vehicle elements of sufficient strength to withstand the forces applied to the device. Driver and/or passenger air bags (SRS) will affect the way equipment should be mounted. This device should be mounted by permanent installation and within the zones specified by the vehicle manufacturer, if any. Any device mounted in the deployment area of an air bag will damage or reduce the effectiveness of the air bag and may damage or dislodge the device. Installer must be sure that this device, its mounting hardware and electrical supply wiring does not interfere with the air bag or the SRS wiring or sensors. Mounting the unit inside the vehicle by a method other than permanent installation is not recommended as unit may become dislodged during swerving; sudden braking or collision. Failure to follow instructions can result in personal injury. Whelen assumes no liability for any loss resulting from the use of this warning device. **PROPER INSTALLATION COMBINED WITH OPERATOR TRAINING IN THE PROPER USE OF EMERGENCY WARNING DEVICES IS ESSENTIAL TO INSURE THE SAFETY OF EMERGENCY PERSONNEL AND THE PUBLIC.**

### Warnings to Users

Whelen's emergency vehicle warning devices are intended to alert other operators and pedestrians to the presence and operation of emergency vehicles and personnel. However, the use of this or any other Whelen emergency warning device does not guarantee that you will have the right-of-way or that other drivers and pedestrians will properly heed an emergency warning signal. Never assume you have the right-of-way. It is your responsibility to proceed safely before entering an intersection, driving against traffic, responding at a high rate of speed, or walking on or around traffic lanes. Emergency vehicle warning devices should be tested on a daily basis to ensure that they operate properly. When in actual use, the operator must ensure that both visual and audible warnings are not blocked by vehicle components (i.e.: open trunks or compartment doors), people, vehicles, or other obstructions. It is the user's responsibility to understand and obey all laws regarding emergency warning devices. The user should be familiar with all applicable laws and regulations prior to the use of any emergency vehicle warning device. Whelen's audible warning devices are designed to project sound in a forward direction away from the vehicle occupants. However, because sustained periodic exposure to loud sounds can cause hearing loss, all audible warning devices should be installed and operated in accordance with the standards established by the National Fire Protection Association.

### Safety First

This document provides all the necessary information to allow your Whelen product to be properly and safely installed. Before beginning the installation and/or operation of your new product, the installation technician and operator must read this manual completely. Important information is contained herein that could prevent serious injury or damage.

**⚠ WARNING:** This product can expose you to chemicals including Methylene Chloride which is known to the State of California to cause cancer, and Bisphenol A, which is known to the State of California to cause birth defects or other reproductive harm. For more information go to [www.P65Warnings.ca.gov](http://www.P65Warnings.ca.gov).

- **Proper installation of this product requires the installer to have a good understanding of automotive electronics, systems and procedures.**
- **Whelen Engineering requires the use of waterproof butt splices and/or connectors if that connector could be exposed to moisture.**
- **Any holes, either created or utilized by this product, should be made both air- and watertight using a sealant recommended by your vehicle manufacturer.**
- **Failure to use specified installation parts and/or hardware will void the product warranty.**
- **If mounting this product requires drilling holes, the installer MUST be sure that no vehicle components or other vital parts could be damaged by the drilling process. Check both sides of the mounting surface before drilling begins. Also de-burr the holes and remove any metal shards or remnants. Install grommets into all wire passage holes.**
- **If this manual states that this product may be mounted with suction cups, magnets, tape or Velcro<sup>®</sup>, clean the mounting surface with a 50/50 mix of isopropyl alcohol and water and dry thoroughly.**
- **Do not install this product or route any wires in the deployment area of your air bag. Equipment mounted or located in the air bag deployment area will damage or reduce the effectiveness of the air bag, or become a projectile that could cause serious personal injury or death. Refer to your vehicle owner's manual for the air bag deployment area. The User/Installer assumes full responsibility to determine proper mounting location, based on providing ultimate safety to all passengers inside the vehicle.**
- **For this product to operate at optimum efficiency, a good electrical connection to chassis ground must be made. The recommended procedure requires the product ground wire to be connected directly to the NEGATIVE (-) battery post (this does not include products that use cigar power cords).**
- **If this product uses a remote device for activation or control, make sure that this device is located in an area that allows both the vehicle and the device to be operated safely in any driving condition.**
- **Do not attempt to activate or control this device in a hazardous driving situation.**
- **This product contains either strobe light(s), halogen light(s), high-intensity LEDs or a combination of these lights. Do not stare directly into these lights. Momentary blindness and/or eye damage could result.**
- **Use only soap and water to clean the outer lens. Use of other chemicals could result in premature lens cracking (crazing) and discoloration. Lenses in this condition have significantly reduced effectiveness and should be replaced immediately. Inspect and operate this product regularly to confirm its proper operation and mounting condition. Do not use a pressure washer to clean this product.**
- **It is recommended that these instructions be stored in a safe place and referred to when performing maintenance and/or reinstallation of this product.**
- **FAILURE TO FOLLOW THESE SAFETY PRECAUTIONS AND INSTRUCTIONS COULD RESULT IN DAMAGE TO THE PRODUCT OR VEHICLE AND/OR SERIOUS INJURY TO YOU AND YOUR PASSENGERS!**

# Table of Contents

**Retro-Fit guidelines for models (with a ZF or 1ZF Power Supply):**  
9004SL, 9004WB, 9801, 9802, 9804, 9806, Mini Edge® .....page 3

**Retro-Fit guidelines for models (with a ZF or 1ZF Power Supply):**  
9104, 9206, 9206WB, 9308, 9308WB, 9000FM .....page 4

**Retro-Fit guidelines for models (with a 5ZF or ZFM Power Supply):**  
9104, 9206, 9206WB, 9308, 9308WB, 9000FM .....page 5

**Retro-Fit guidelines for models (with a ZFO, 1ZFO or 2ZFO Power Supply):**  
9104, 9206, 9308, 9000FM, 9206WB .....page 6

**EB6 Power Supply and Adaptor Harness Information .....page 7**

**EB6 Specification Table .....page 7**

**Adaptor Cable Usage Table .....page 7**

## Section 1; Retro-Fit guidelines for the following:

### Models:

9004SL, 9004WB, 9801, 9802,  
9804, 9806, Mini Edge®

### With Power Supply:

ZF or 1ZF

#### **WARNING!!!**

The strobe light power supply is a **HIGH VOLTAGE** device. You must wait at least 10 minutes after turning off the power to the system before starting any diagnostic or trouble shooting procedures that may bring you into contact with any internal components.

### **Removal of Existing Power Supply...**

1. Remove endcap and lenses until you have access to your lightbar's power supply. Power supply is located in the center section of your lightbar.
2. Locate the three harness plugs that connect to the existing power supply. As shown in Fig.1, the function of each plug is indicated by the outlet to which it was connected.

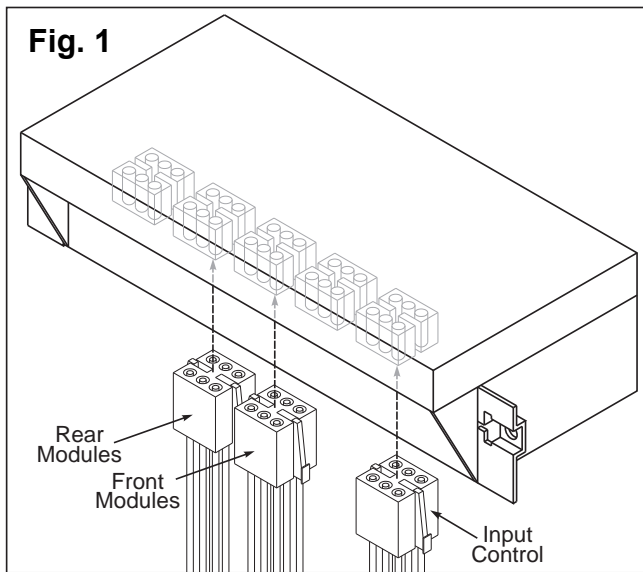

3. Label each of the three plugs by their function. This is important, as this will determine how these plugs are connected to the new power supply.
4. With the plugs disconnected from the old power supply, remove the two screws that hold the power supply in position.
5. Remove power supply from lightbar.

### **Installation of New Power Supply...**

1. Before the new power supply can be installed in the lightbar, two harness adaptors must be added as follows.

2. Locate the "ZF Input Harness Adaptor" shown in Fig. 2 (P/N - 46-0741909-00). Install the 8 position end onto Plug 1. **NOTE - Make sure that the adaptor harness is installed so that the wire colors in Plug 1 are lined up with the wire colors in the adaptor harness.**
3. Locate the "2ZFO/ZF Output Harness Adaptor" shown in Fig. 2 (P/N - 46-0741908-00). This adaptor will be connected to plugs 2 & 3 of the new power supply. As the ends of this adaptor are identical, it doesn't matter which end is plugged into the power supply. **NOTE - Make sure that the adaptor harness is installed so that the wire colors of the adaptor plugs are lined up with the wire colors of the power supply's plugs.**
4. With the appropriate adaptor harnesses plugged onto the new power supply, the new power supply can now be connected to the lightbar. Locate the harness plugs that were connected to the old power supply and connect to the adaptor harnesses as follows:

Connect	<b>POWER</b>	to	<b>PLUG 1</b>
Connect	<b>REAR MODULES</b>	to	<b>PLUG 2</b>
Connect	<b>FRONT MODULES</b>	to	<b>PLUG 3</b>

5. The new power supply may now be mounted in the lightbar. Position the new power supply in its mounting location. This will be a tight fit and will require a small amount of effort to properly mount the new power supply. **NOTE: If harness wraps are present on the old lightbar plug harnesses, it may be necessary to carefully cut and remove these wraps in order for the power supply to fit into the extrusion.**
6. Secure the power supply to the lightbar using the old power supply's mounting screws. **NOTE: Apply Loctite™ #242 to the threads of each mounting screw.**
7. Test the lightbar for proper operation. After a successful test, the lightbar may be reassembled in the reverse order in which it was disassembled.
8. If the lightbar does not function properly, disconnect the lightbar from its power source, wait 10 minutes to avoid the risk of a high voltage shock and confirm that the proper plugs are connected. If the plugs connections are correct, contact your Whelen representative for further assistance.

## Section 2; Retro-Fit guidelines for the following:

### Models:

9104, 9206, 9206WB, 9308,  
99308WB, 9000FM

### With Power Supply:

ZF or 1ZF

#### **WARNING!!!**

The strobe light power supply is a **HIGH VOLTAGE** device. You must wait at least 10 minutes after turning off the power to the system before starting any diagnostic or trouble shooting procedures that may bring you into contact with any internal components.

### **Removal of Existing Power Supply...**

1. Remove endcap and lenses until you have access to your lightbar's power supply. Power supply is located in the center section of your lightbar.
2. Locate the three harness plugs that connect to the existing power supply. As shown in Fig. 1, the function of each plug is indicated by the outlet to which it was connected.

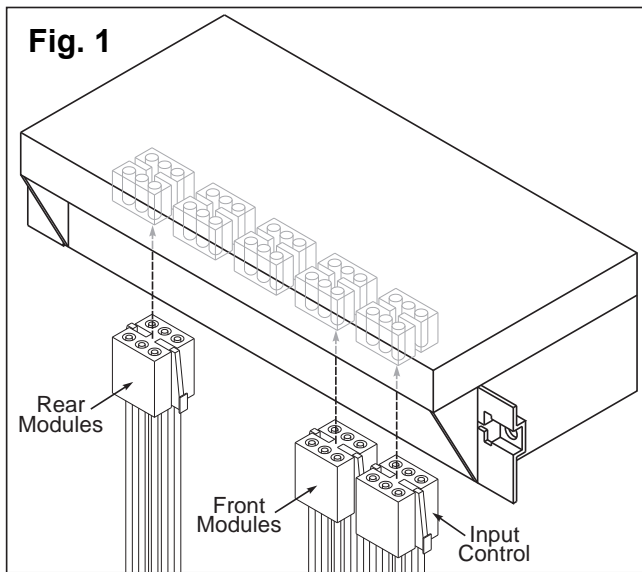

3. Label each of the three plugs by their function. This is important, as this will determine how these plugs are connected to the new power supply.
4. With the plugs disconnected from the old power supply, remove the two screws that hold the power supply in position.
5. Remove power supply from lightbar.

### **Installation of New Power Supply...**

1. Before the new power supply can be installed in the lightbar, two harness adaptors must be added as follows.

2. Locate the "6 to 8 pin ZF Input Harness Adaptor" shown in Fig. 2 (P/N - 46-0745815-00). Install the 8 position end onto Plug 1. **NOTE - Make sure that the adaptor harness is installed so that the wire colors in Plug 1 are lined up with the wire colors in the adaptor harness.**
3. Locate the "2ZF0/ZF Output Harness Adaptor" shown in Fig. 2 (P/N - 46-0741908-00). This adaptor will be connected to plugs 2 & 3 of the new power supply. As the ends of this adaptor are identical, it doesn't matter which end is plugged into the power supply. **NOTE - Make sure that the adaptor harness is installed so that the wire colors of the adaptor plugs are lined up with the wire colors of the power supply's plugs.**
4. With the appropriate adaptor harnesses plugged onto the new power supply, the new power supply can now be connected to the lightbar. Locate the harness plugs that were connected to the old power supply and connect to the adaptor harnesses as follows:

Connect	<b>POWER</b>	to	<b>PLUG 1</b>
Connect	<b>REAR MODULES</b>	to	<b>PLUG 2</b>
Connect	<b>FRONT MODULES</b>	to	<b>PLUG 3</b>

5. The new power supply may now be mounted in the lightbar. Position the new power supply in its mounting location. This will be a tight fit and will require a small amount of effort to properly mount the new power supply. **NOTE: If harness wraps are present on the old lightbar plug harnesses, it may be necessary to carefully cut and remove these wraps in order for the power supply to fit into the extrusion.**
6. Secure the power supply to the lightbar using the old power supply mounting screws. **NOTE: Apply Loctite™ #242 to the threads of each mounting screw.**
7. Test the lightbar for proper operation. After a successful test, the lightbar may be reassembled in the reverse order in which it was disassembled.
8. If the lightbar does not function properly, disconnect the lightbar from its power source, wait 10 minutes to avoid the risk of a high voltage shock and confirm that the proper plugs are connected. If the plugs connections are correct, contact your Whelen representative for further assistance.

### Section 3; Retro-Fit guidelines for the following:

#### Models:

9104, 9206, 9206WB, 9308,  
9308WB, 9000FM

#### With Power Supply:

5ZF or ZFM

#### **WARNING!!!**

The strobe light power supply is a **HIGH VOLTAGE** device. You must wait at least 10 minutes after turning off the power to the system before starting any diagnostic or trouble shooting procedures that may bring you into contact with any internal components.

#### ***Removal of Existing Power Supply...***

1. Remove endcap and lenses until you have access to your lightbar's power supply. Power supply is located in the center section of your lightbar.
2. Locate and remove the two screws that hold the power supply in position and remove the power supply from the lightbar.
3. Locate the five harness plugs that connect to the existing power supply. As shown in Fig. 1, four function plugs are connected to color-labeled outlets at one end of the power supply, while a larger plug is connected to a fused plug at the other end.

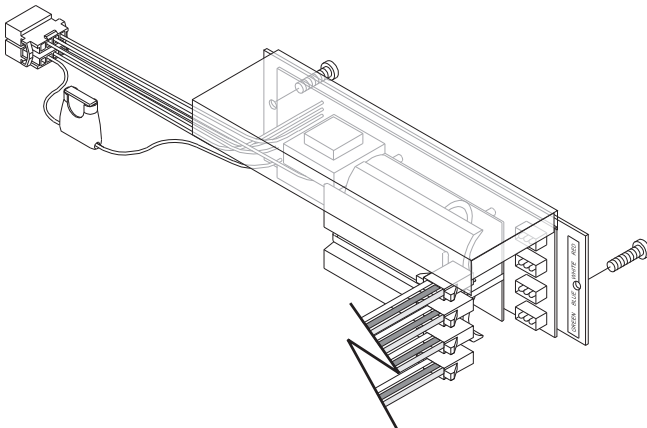

4. Each of the function plugs has a key wire whose color corresponds to the color label for that plug's outlet. Take note of each plug's key color, as it will be used to identify that plug for connection to the new power supply.

#### ***Installation of New Power Supply...***

1. Before the new power supply can be installed in the lightbar, two harness adaptors must be added as follows.
2. Locate the "6 to 8 pin ZF Input Harness Adaptor" shown in Fig. 2 (P/N - 46-0745815-00). Install the 8

position end onto Plug 1. **NOTE - Make sure that the adaptor harness is installed so that the wire colors in Plug 1 are lined up with the wire colors in the adaptor harness.**

3. Locate the "2ZFO/ZF Output Harness Adaptor" shown in Fig. 2 (P/N - 46-0745715-00). This adaptor will be connected to plugs 2 & 3 of the new power supply. **NOTE - Make sure that the adaptor harness is installed so that the wire colors of the adaptor plugs are lined up with the wire colors of the power supply's plugs.**
4. With the appropriate adaptor harnesses plugged onto the new power supply, the new power supply can now be connected to the lightbar. Connect the lightbar's 6-position power plug to the input harness adaptor. Now locate the harness plugs that were connected to the old power supply and connect to the adaptor harness as follows:

#### Lightbar Plug with:

**RED WIRE**  
**WHITE WIRE**  
**BLUE WIRE**  
**GREEN WIRE**

to  
to  
to  
to

#### Adaptor Plug with:

**RED WIRE**  
**WHITE WIRE**  
**BLUE WIRE**  
**GREEN WIRE**

5. The new power supply may now be mounted in the lightbar. Position the new power supply in its mounting location. This will be a tight fit and will require a small amount of effort to properly mount the new power supply. **NOTE: If harness wraps are present on the old lightbar plug harnesses, it may be necessary to carefully cut and remove these wraps in order for the power supply to fit into the extrusion.**
6. Secure the power supply to the lightbar using the old power supply's mounting screws. **NOTE: Apply Loctite™ #242 to the threads of each mounting screw.**
7. Test the lightbar for proper operation. After a successful test, the lightbar may be reassembled in the reverse order in which it was disassembled.
8. If the lightbar does not function properly, disconnect the lightbar from its power source, wait 10 minutes to avoid the risk of a high voltage shock and confirm that the proper plugs are connected. If the plugs connections are correct, contact your Whelen representative for further assistance.

## Section 4; Retro-Fit guidelines for the following:

### Models:

9104, 9206, 9308,  
9000FM, 9206WB

### With Power Supply:

ZFO, 1ZFO or 2ZFO

#### **WARNING!!!**

The strobe light power supply is a **HIGH VOLTAGE** device. You must wait at least 10 minutes after turning off the power to the system before starting any diagnostic or trouble shooting procedures that may bring you into contact with any internal components.

### **Removal of Existing Power Supply...**

1. Remove endcap and lenses until you have access to your lightbar's power supply. Power supply is located in the center section of your lightbar.
2. Locate and remove the two screws that hold the power supply in position and remove the power supply from the lightbar.

Fig. 1

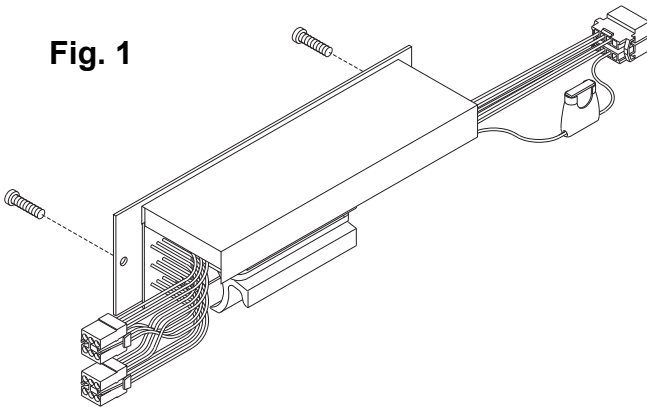

3. Locate the three harness plugs that connect to the existing power supply. Before disconnecting these plugs from the power supply, write down each of the wire colors that were connected to each plug. This is important, as this will determine how these plugs are connected to the new power supply.
4. Remove power supply from lightbar.

### **Installation of new Power Supply...**

1. The new power supply is connected to the lightbar without any adaptor cables. When connecting the lightbar plugs to the new power supply, make sure that the wire colors match exactly.
2. The new power supply may now be mounted in the lightbar. Position the new power supply in its mounting location. This may be a tight fit and could require a small amount of effort to properly mount the new power supply. **NOTE: If harness wraps are present on the old lightbar plug harnesses, it may be necessary to carefully cut and remove these wraps in order for the power supply to fit into the extrusion.**
3. Secure the power supply to the lightbar using the old power supply's mounting screws. **NOTE: Apply Loctite™ #242 to the threads of each mounting screw.**
4. Test the lightbar for proper operation. After a successful test, the lightbar may be reassembled in the reverse order in which it was disassembled.
5. If the lightbar does not function properly, disconnect the lightbar from its power source, wait 10 minutes to avoid the risk of a high voltage shock and confirm that the proper plugs are connected. If the plugs connections are correct, contact your Whelen representative for further assistance.

# SPECIFICATIONS

INPUT VOLTAGE	- 13.5 VDC ±20%
INPUT CURRENT OFF	- 0 AMPS
INPUT CURRENT 30 WATTS	- 3 AMPS (TYP)
INPUT CURRENT 60 WATTS	- 6 AMPS (TYP)
INPUT CURRENT 90 WATTS	- 9 AMPS (TYP)
FLASHRATE (CometFlash®)	- 75 FPM (PER LAMP) @ 85 ms
FLASHRATE (DOUBLEFLASH)	- 110 FPM (PER LAMP) @ 100 ms
FLASHRATE (SINGLEFLASH)	- 240 FPM (PER LAMP)
FLASHRATE (SEQUENTIAL)	- 3 CYCLES (COMET) > 4 CYCLES (SF)
INPUT CONTROL VOLTAGE	- 13.5 VDC ±20%
INPUT CONTROL CURRENT	- 50 MA (TYP)
ENERGY 30 WATT MODE	- 12.5 JOULES (TOTAL) 5/2.5/2.5/2.5 JOULES
ENERGY 60 WATT MODE	- 26.5 JOULES (TOTAL) 11.5/5/5/5 JOULES
ENERGY 90 WATT MODE	- 36 JOULES (TOTAL) 15/7/7/7 JOULES
ENERGY LO POWER MODE	- 10 JOULES (TOTAL) 2.5/2.5/2.5/2.5 JOULES

IF YOU HAVE LIGHTBAR #:	WITH POWER SUPPLY #:	USE ADAPTOR CABLES:
9004SL, 9004WB, 9801, 9802, 9804, 9806, Mini Edge®	ZF, 1ZF	46-0741909-00 46-0741908-00
9104, 9206, 9206WB, 9308, 9308WB, 9000FM	ZF, 1ZF	46-0741908-00 46-0745815-00
9104, 9206, 9206WB, 9308, 9308WB, 9000FM	5ZF, ZFM	46-0745715-00 46-0745815-00
9104, 9206, 9308, 9000FM, 9206WB	ZFO, 1ZFO, 2ZFO	NONE

## Plug 1: Input Control

PIN #	COLOR	FUNCTION	CONTROL
1	BLUE	P2 & P4 ENABLE	13.5 VDC 20%
2	VIOLET	LOW POWER	GROUND - HI POWER N/C - LO POWER
3	GREEN	P3 ENABLE	13.5 VDC 20%
4	GREY	TURBO	13.5 VDC 20%
5	RED	INPUT VOLTAGE	13.5 VDC 20%
6	BLACK	GROUND	GROUND
7	BROWN	PATTERN 1	13.5 VDC 20%
8	WHITE	PATTERN 2	13.5 VDC 20%

Fig. 2

## Plug 2: Front Modules

PIN #	COLOR	FUNCTION
1	ORANGE	ANODE
2	ORANGE	ANODE
3	BLACK/WHITE	CATHODE
4	BLACK/WHITE	CATHODE
5	GREEN	TRIGGER
6	WHITE	TRIGGER

## Plug 3: Rear Modules

PIN #	COLOR	FUNCTION
1	ORANGE	ANODE
2	ORANGE	ANODE
3	BLACK/WHITE	CATHODE
4	BLACK/WHITE	CATHODE
5	BLUE	TRIGGER
6	RED	TRIGGER

## Plug 4: Aux Modules

PIN #	COLOR	FUNCTION
1	ORANGE	ANODE
2	ORANGE	ANODE
3	BLACK/WHITE	CATHODE
4	BLACK/WHITE	CATHODE
5	VIOLET	TRIGGER
6	GREY	TRIGGER

